

Middle Trolley(30)

C30MC-60



Towing Trolley(C30)

C30SC-60

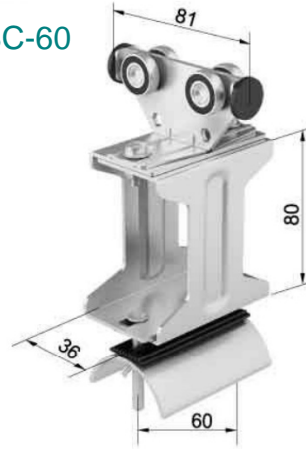

Type	C32MC-75	C32SC-60
Wheels	Ball bearing, hardened, galvanized Temperature resistance Lub. grease of wheel:-30 Traveling Speed: ca. 120m/min.	°Cto+125°C
Material	Carrier body: steel, galvanized Support saddle:steel, galvanized Bumper:Neoprene Dowel: Steel,galvanized Hardware: galvanized Temperature resistance:-30	°Cto+100°C
Max.cable load	Max.20 kg per carrier	Max.20 kg per carrier
Dim.of Cable (mm)	max. 60W×32δ	max. 60W×32δ
Weight(kg)	0.35	0.63
Cat.-NO.	701201	701101

End Trolley (30)

C30EC-60



Type	C30EC-60
Material	Carrier body: steel, galvanized Support saddle:steel, galvanized Bumper:steel, galvanized Hardware: galvanized
Max.cable load	Max.22 kg per carrier
Dim.of Cable (mm)	Max.d=50mm/D=80mm/D=160mm
Weight(kg)	0.29
Cat.-NO.	711206(D=50,L=160) 711208(D=80,L=190) 711210(D=60,L=270)

Hanger C30DJ

for C-track Support Bracket

C30DJ-2

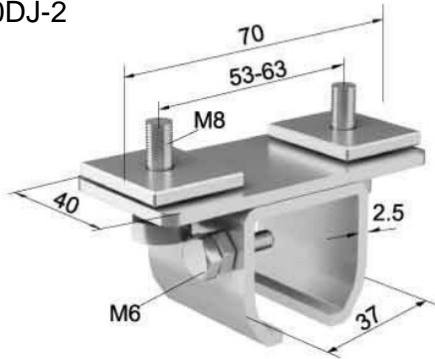

Type	Weight kg	Material	Order-No.
C32DJ-2	0.208	Galvanized steel	704102

ready installed

Hanger C30DJ

C30DJ-5

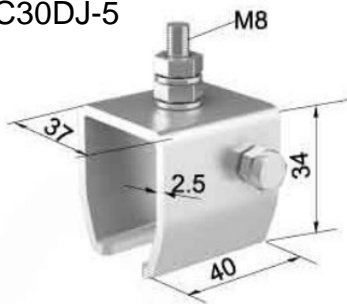

Type	Weight kg	Material	Order-No.
C32DJ-5	0.176	Galvanized steel	704105

Joint Clamp C30JT

C30JT-1

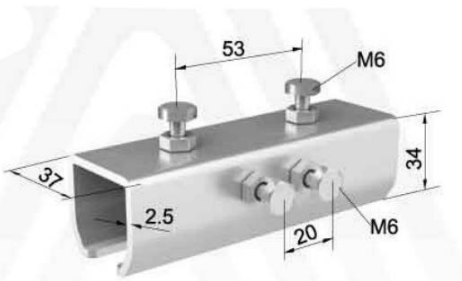

Type	Weight kg	Material	Order-No.
C32DJ-1	0.358	Galvanized steel	723401

ready installed

Middle Trolley (40)

C40MC



Towing Trolley (40)

C40SC



Type	C40MC	C40SC
Wheels	Ball bearing, hardened, galvanized Temperature resistance Lub. grease of wheel:-30 Traveling Speed: ca. 160m/min.	°Cto+125°C
Material	Carrier body: steel, galvanized Support saddle:steel, galvanized or ABS Bumper:Neoprene Dowel: Steel,galvanized Hardware: galvanized Temperature resistance:-30	°Cto+100°C
Max.cable load	max.35 kg per carrier	max.35 kg per carrier
Dim.of Cable (mm)	max. 75W×32δ	max. 75W×32δ
Weight(kg)	0.522	0.655
Cat.-NO.	7210201,721202(R=50,ABS)	721101,721102(R=50,ABS)

Trolley for Round Cable

C40RMC

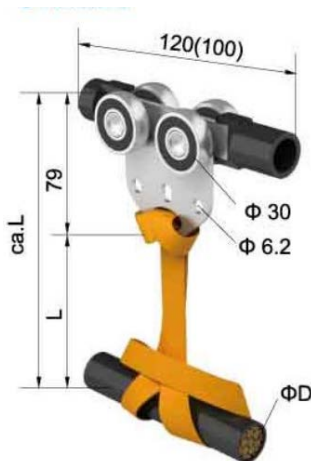

Type	C40RMC
Wheels	Ball bearing, hardened, galvanized Temperature resistance Lub. grease of wheel:-30 Traveling Speed: ca. 160m/min.
Material	Carrier body: steel, galvanized Sling:Nylon Dowel: Brass Hardware: galvanized
Max.cable load	28 kg per carrier
Dim.of Cable	D=50mm/D=80mm/D=160mm
Weight(kg)	0.33
Cat.-NO.	711206(D=50,L=160) 711208(D=80,L=190) 711210(D=60,L=270)

Hanger C40DJ for C-track Support Bracket

C40DJ-1

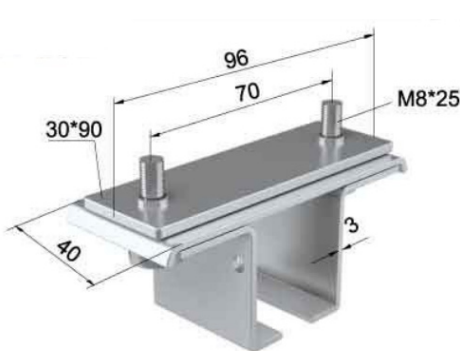

C40DJ-2

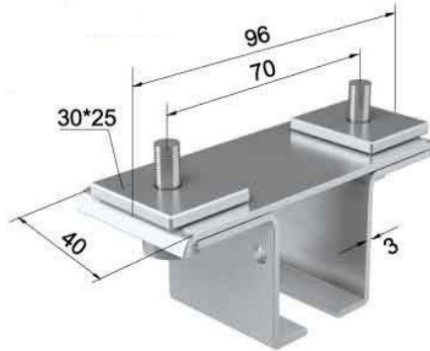

ready installed

Type	Weight kg	Material	Order-No.
C40DJ-1	0.298	Galvanized steel	704101
C40DJ-2	0.272	Galvanized steel	704102

Hanger C40DJ for Angle steel Support Bracket

C40DJ-5

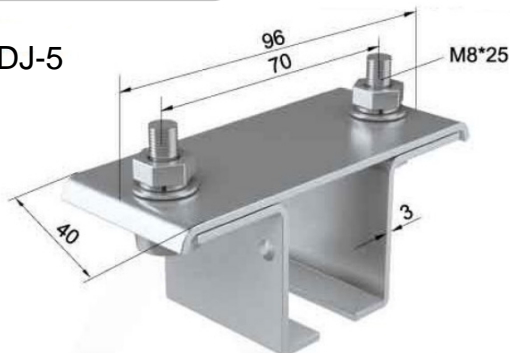

ready installed

Type	Weight kg	Material	Order-No.
C40DJ-5	0.215	Galvanized steel	724105

Joint Clamp C40JT

C40JT-1

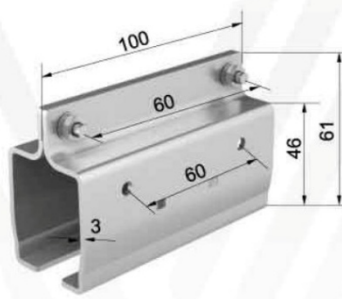
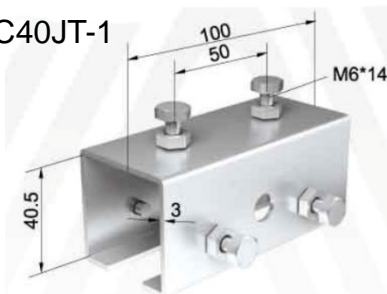

C40JT-2



ready installed

Type	Weight kg	Material	Order-No.
C40JT-1	0.348	Galvanized steel	723401
C40JT-2	0.318	Galvanized steel	23402

Middle Trolley (63)

C63MC

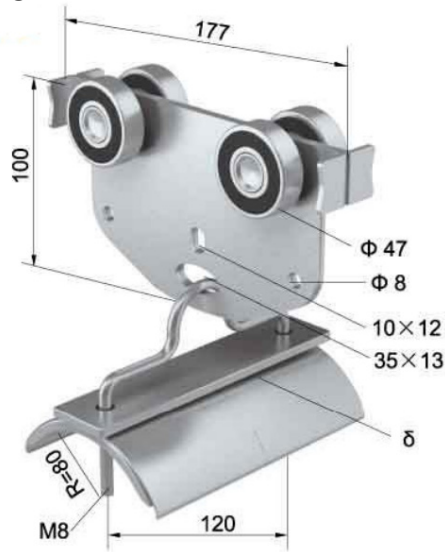

Towing Trolley (63)

C63SC



Type	C63MC	C63SC
Wheels	Ball bearing, hardened, galvanized Temperature resistance Lub. grease of wheel:-30 °Cto+125°C Traveling Speed: ca. 160m/min.	
Material	Carrier body: steel, galvanized Support saddle: steel, galvanized Dowel: Steel, galvanized Hardware: galvanized Temperature resistance:-30 °Cto+100°C	
Max.cable load	Max.65 kg per carrier	Max.65 kg per carrier
Dim.of Cable (mm)	max. 120W×40δ	max. 120W×40δ
Weight(kg)	1.96	2.28
Cat.-NO.	751201	751101

End Trolley (63)

C63MC



Type	C63EC
Material	steel, galvanized
Max.cable load	max.65 kg per carrier
Dim.of Cable	max. 120W×40δ
Weight(kg)	1.15
Cat.-NO.	751301

Hanger C63DJ

C63DJ

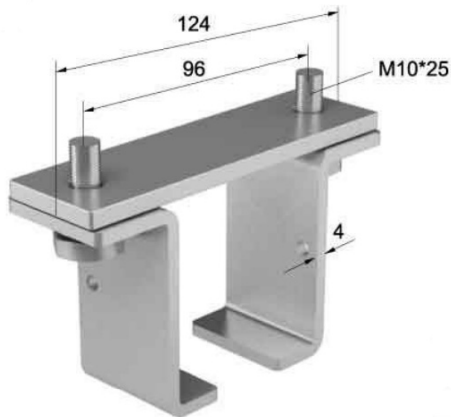

ready installed

Type	Weight kg	Material	Order-No.
C63DJ	0.465	Galvanized steel	754102

Clamp C63DJ

C63DJ

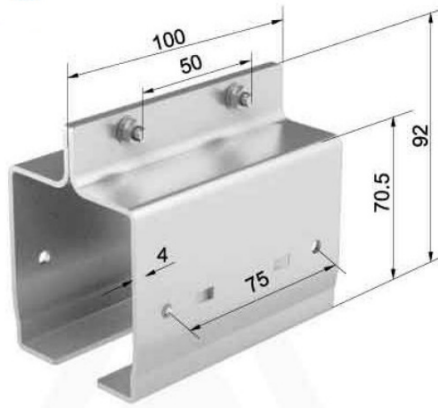

ready installed

Type	Weight kg	Material	Order-No.
C63DJ	0.465	Galvanized steel	754102

End Stop C63DZ

C32DZ-1

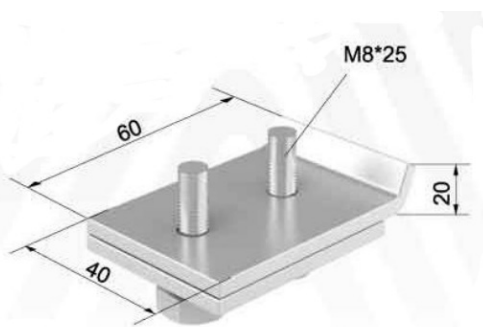

ready installed

Type	Weight kg	Material	Order-No.
C63DZ	0.46	Galvanized steel	753702

Ready installed on C-Track Bracket (for welding)

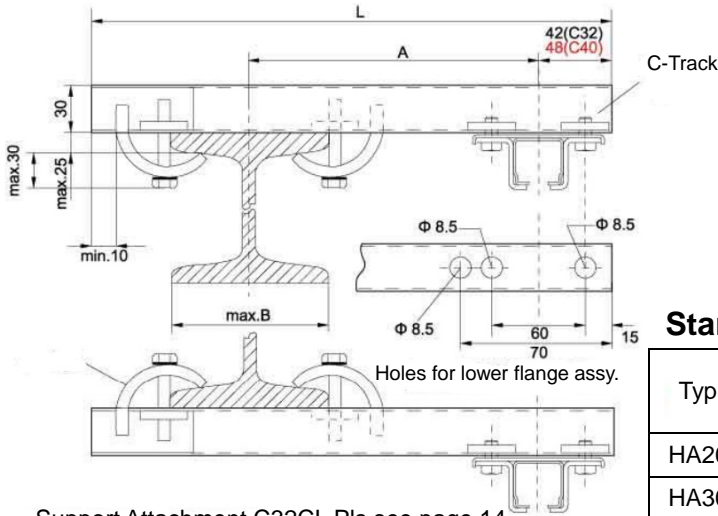

Support Attachment C32CL Pls see page 14

Choose dim. A per local requirements and make sure that hoist wheels have enough clearance.

Dim. 70 mm is C40 Track Hanger.

Select next larger size bracket when your -Beam dim. B is more than 210 mm and refer to heavy duty brackets.

Standard Bracket

Type	Material	A mm*	L mm	Max B mm	Cat-NO.
HA200	Galvanized steel	200	400	210	714151
HA300		300	500	210	714152
HA400		400	600	210	714153
HA500		500	700	210	714154

upper flange assy

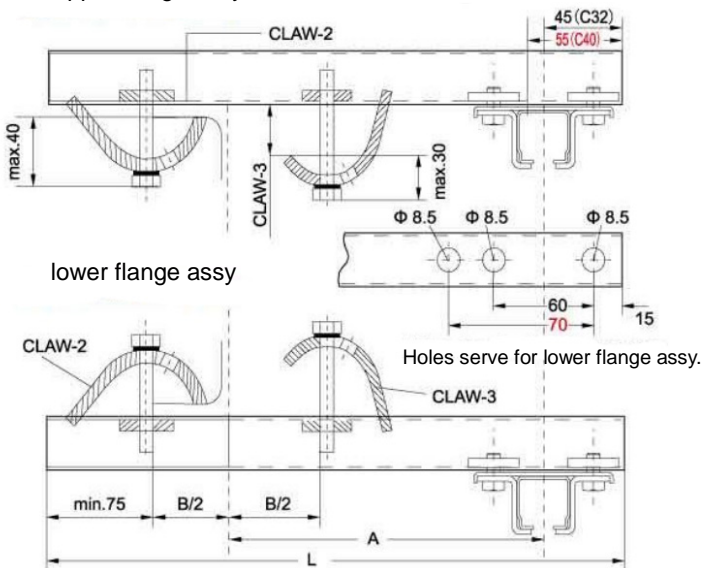

The track sections are provided with borings to fix the support hangers at the bottom flange of the track profile.

Heavy duty Bracket

Type	Material	L mm	Cat-NO.
HL400	Galvanized steel	400	714161
HL500		500	714162
HL600		600	714163
HL700		700	714164
HL800		800	714165
HL900		900	714166
HL1000		1000	714167
HL1100		1100	714168
HL1200		1200	714169

Claw C40CL pls see Page 61

C-Track Bracket (for welding)

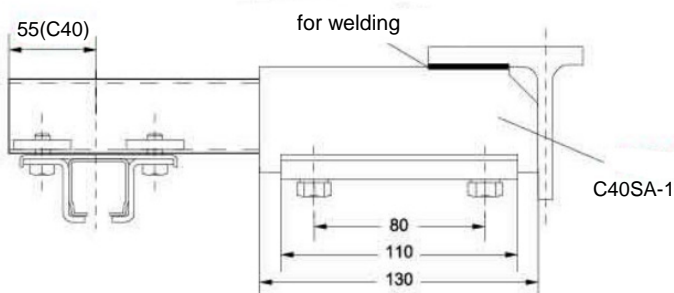

Angle steel Bracket (for welding)

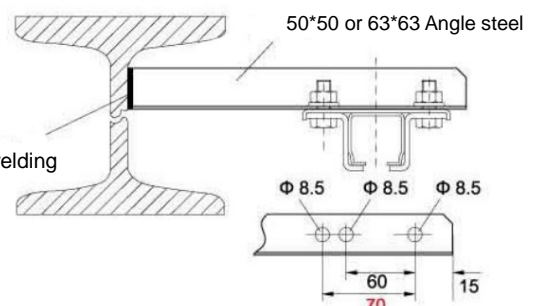

Claw (C32/C40)

C32CL-1

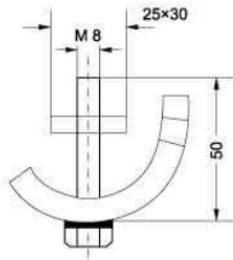
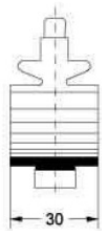

C40CL-1

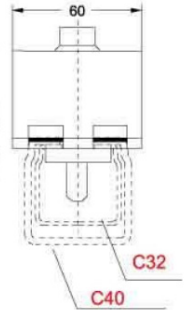
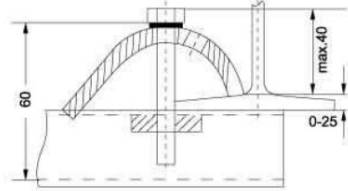

C40CL-2

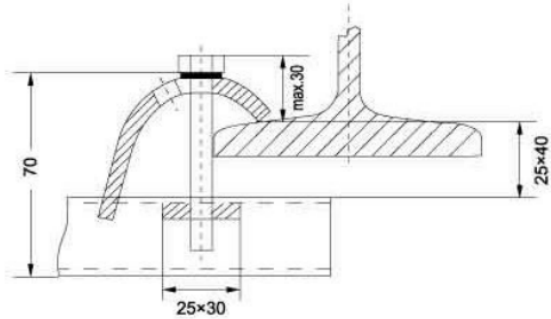

Type	Weight kg	Material	Order- NO.
C32CL-1	0.202	Galvanized steel	714181
C40CL-1	0.281		714181
C40CL-2	0.285		714182

Be used for Heavy duty Bracket

Support Attachment (C40)



C40SA-2

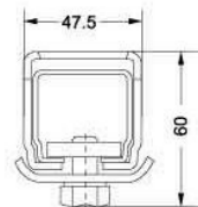
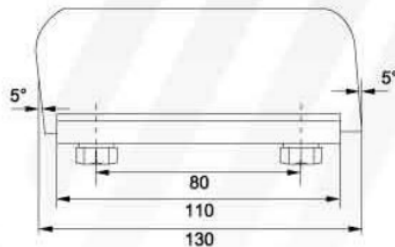
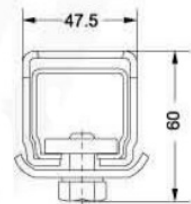
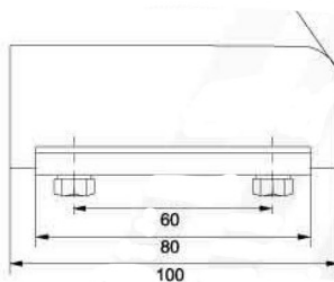

Type	Weight kg	Material	Cat.- NO.
C40SA-1	0.936	Galvanized steel	714191
C40SA-2	0.951		714192